

Festoon Systems for Wire Ropes

Program 0210/0215

Cat 01-2021-WR1



Your Applications - our Solutions!

Festoon Systems by Conductix-Wampfler are only one part of the wide range of the Conductix-Wampfler energy, data and air/fluid supply systems. The right solution for your application is always dependant on the specific situation.

Many times, it is the precise combination of several Conductix-Wampfler systems that will yield the best results. You will find consulting and engineering competence in our companies and subsidiaries worldwide - a perfect complement to our wide array of products and systems.



Festoon systems

It is hard to imagine Conductix-Wampfler cable trolleys not being used in virtually every industrial application: They are reliable and robust in an enormous variety of dimensions and designs.



Cable reels

Motorized and spring cable reels by Conductix-Wampfler are proven solutions wherever energy, data and media have to cover the most diverse distances within a short amount of time - in all directions, fast and safe.



Slip ring assemblies

Whenever things are really "moving in circles", the proven slip ring assemblies by Conductix-Wampfler ensure the flawless transfer of energy and data. Here, everything revolves around flexibility and reliability!



Conductor rails

Whether they are enclosed conductor rails or expandable single-pole systems, the proven conductor rails by Conductix-Wampfler reliably move people and material.



Non-insulated conductor rails

Extremely robust, non-insulated conductor rails with copper heads or stainless steel surfaces provide the ideal basis for rough applications, for example in steel mills or shipyards.



Energy guiding chains

The "Jack of all trades" when it comes to transferring energy, data, air and fluid hoses. With their wide range, these energy guiding chains are the ideal solution for many industrial applications.



Inductive Power Transfer IPT

The no-contact system for transferring energy and data. For all tasks that depend on high speeds and absolute resistance to wear.

Contents

Ropes and Accessories Program 0210 and 0215	
System Components for Wire Ropes with Diameter 6-12mm	2
Wire Ropes	2
Straining Buckles	3
Strainer Brackets	3

Cable Trolleys for Flat Cables Program 0210	
Festoon Systems for Flat Cables on Rope with Diameter 6mm	4
Plastic Cable Trolleys with Load Capacity up to 6kg	4
Cable Support	5
End Clamp	5
Towing Trolley with Rope Guidance	5

Cable Trolleys for Flat Cables Program 0215	
Festoon Systems for Flat Cables on Ropes with Diameter 8-12mm	6
Plastic Cable Trolley with Load Capacity up to 10kg	6
Plastic Cable Trolley with Load Capacity up to 20kg	6
End Clamp	7
Towing Trolley with Rope Guidance	7
Towing Arm	7

Cable Trolleys for Round Cables and Hoses Program 0210	
Festoon Systems for Round Cables on Rope with Diameter 6mm	8
Plastic Cable Trolley with Hook or Eye with Load Capacity up to 3kg	8
Plastic Cable Trolley with Hook or Eye with Load Capacity up to 6kg	8
Plastic Cable Trolley with Ball Joint with Load Capacity up to 6kg	9
End Clamp	9
Cable Clips for Trolleys with Hook or Ball Joint	9
Cable Support and Towing Arm	9
Towing Trolley with Rope Guidance	9

Cable Trolleys for Round Cables and Hoses Program 0215	
Festoon Systems for Round Cables on Ropes with Diameter 8-12mm	10
Plastic Cable Trolley with Load Capacity up to 10kg	10
Plastic Cable Trolley with Load Capacity up to 20kg	10
End Clamp	11
Towing Trolley with Rope Guidance	11
Supplements to the Program on Inquiry	11

Helpful Hints	
Calculation of Tensile Force	12
Determination of Rope Load and Selection of Required Rope	12

Ropes and Accessories Program 0210 and 0215

System Components for Wire Ropes with Diameter 6-12 mm

System Components
for Rope \varnothing 6 mm

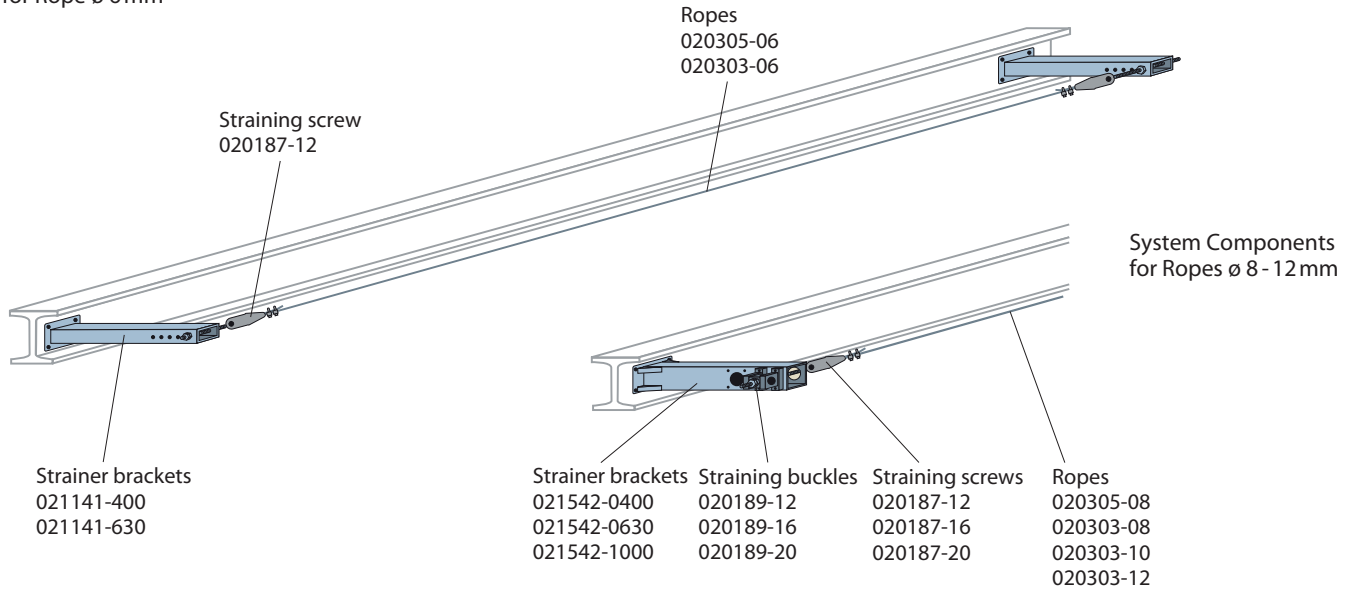

Wire Ropes

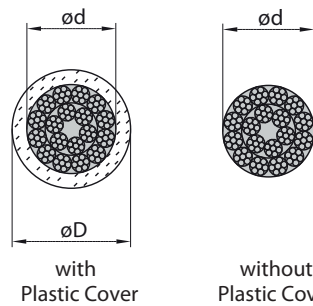

Material
• Rope: galvanized steel
• Cover: plastic

Note
Plastic covered ropes 020305 have the best performance.

Part No.	Type	$\varnothing d$ [mm]	$\varnothing D$ [mm]	Min. Brak. Strength F_{Br} [kN]	Perm. Tensile Strength F_{zul} [kN]	for Straining Screw
020305-06	with plastic cover	4	6	14.5	3.6	020187-12
020303-06	without plastic cover	6	-	20.3	5.1	020187-12
020305-08	with plastic cover	6	8	20.3	5.1	020187-12
020303-08	without plastic cover	8	-	37.2	9.3	020187-12
020303-10		10	-	58.1	14.5	020187-16
020303-12		12	-	81.2	20.3	020187-20

Straining Screws

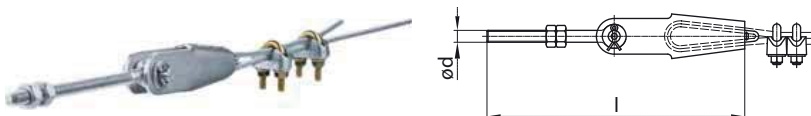

Order No.	$\varnothing d$	l [mm]	for Rope \varnothing [mm]
020187-12	M 12	330	6 - 8
020187-16	M 16	424	10
020187-20	M 20	458	12

Material: galvanized steel

Ropes and Accessories

Program 0210 and 0215

Straining Buckles

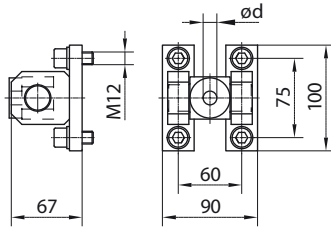

Part No	ϕd [mm]	suitable Strainer Bracket
020189-12	13	021542
020189-16	17	
020189-20	21	

Material: galvanized steel
Application: for flexible reception of the straining screw

Strainer Brackets

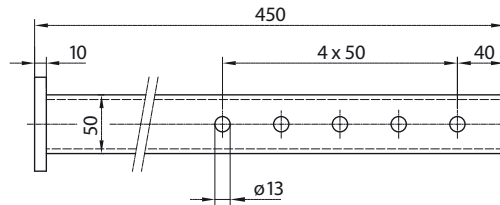
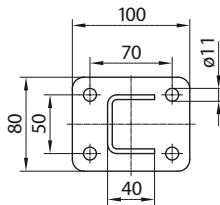

Part No : 021141-400
Material: galvanized steel

Suitable straining screw 020187-12

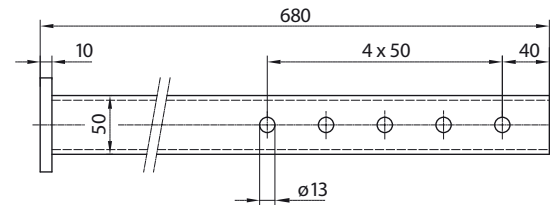
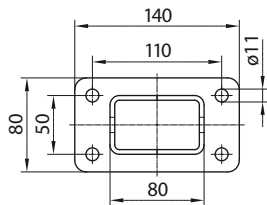

Part No : 021141-630
Material: galvanized steel

Suitable straining screw 020187-12

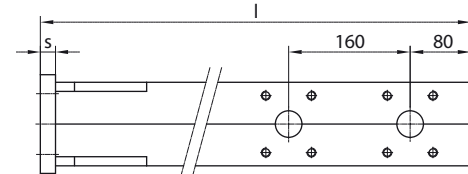
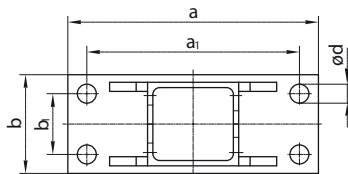

Part No	l [mm]	a [mm]	b [mm]	a ₁ [mm]	b ₁ [mm]	ϕd [mm]	s [mm]
021542-0400	495	290	120	250	80	21	15
021542-0630	730	330	130	280	80	25	20
021542-1000	1105	390	150	330	90	31	25

Material: galvanized steel

Notes

- To be ordered only in connection with straining buckle 020189
- This strainer bracket is also used with two ropes running in parallel
Distance between ropes = 160 mm

Cable Trolleys for Flat Cables

Program 0210

Festoon Systems for Flat Cables on Rope with Diameter 6 mm

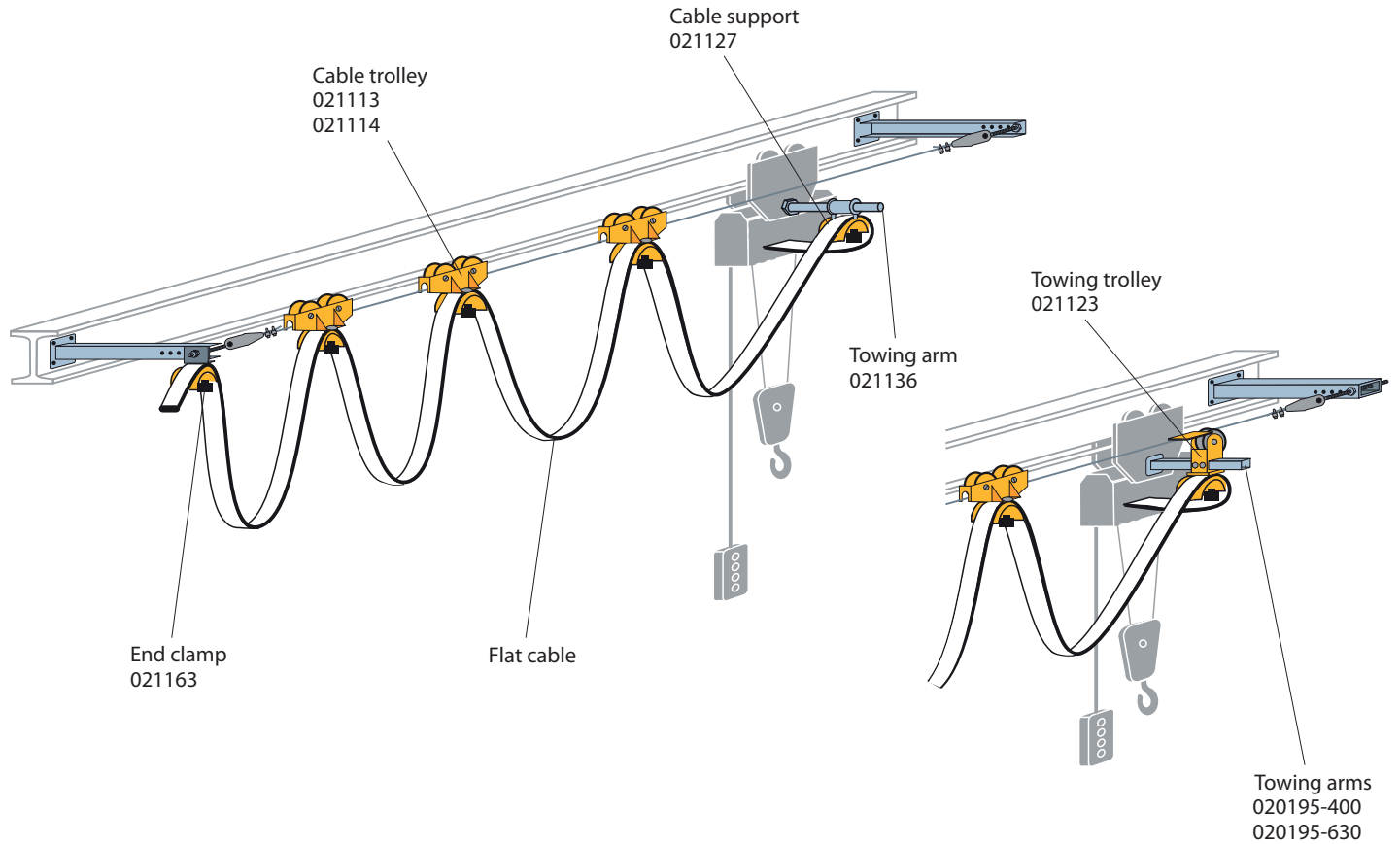

Plastic Cable Trolleys with Load Capacity up to 6 kg

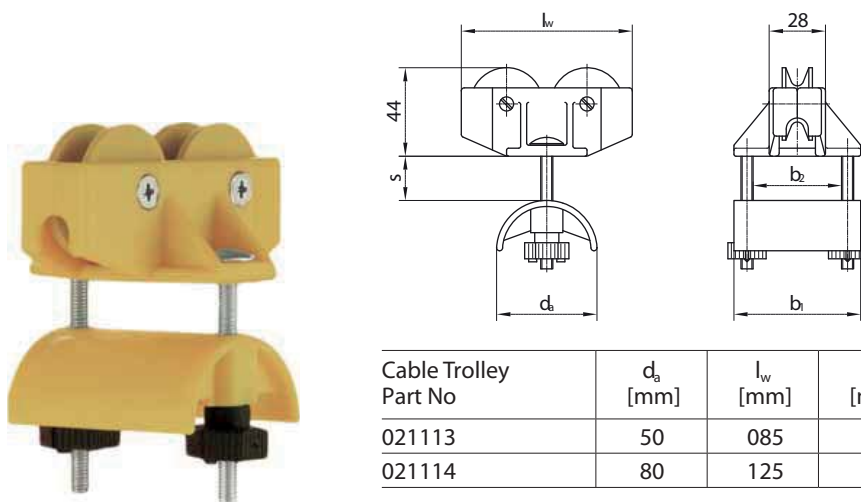

Cable Trolley Part No	d_b [mm]	l_w [mm]	b_1 [mm]	b_2 [mm]	s [mm]
021113	50	085	63	44	17
021114	80	125	80	54	22

- Type of roller:
 - roller: plastic
 - axle: stainless steel
- Load capacity: 6 kg

Flat Cable Trolleys Program 0210

Cable Support

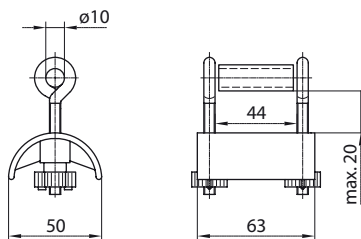

Cable support

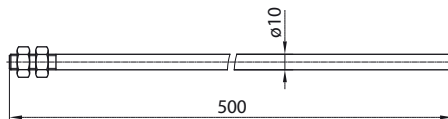

Towing arm

Part No : 021127

Towing Arm
Part No : 021136
Material: galvanized steel

End Clamp

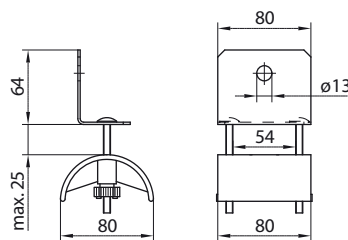

Part No : 021163

Towing Trolley with Rope Guidance

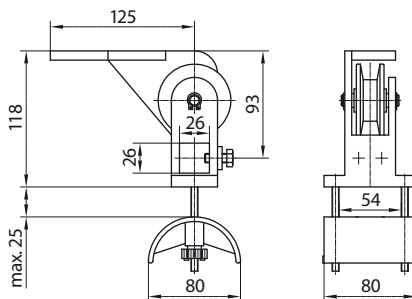

Towing trolley

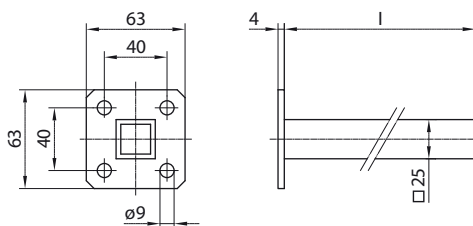

Towing arm

Part No : 021123

Towing Arm Part No .	l [mm]	Material
020195-400	400	galvanized steel
020195-630	630	

Cable Trolleys for Flat Cables

Program 0215

Festoon Systems for Flat Cables on Ropes with Diameter 8-12 mm

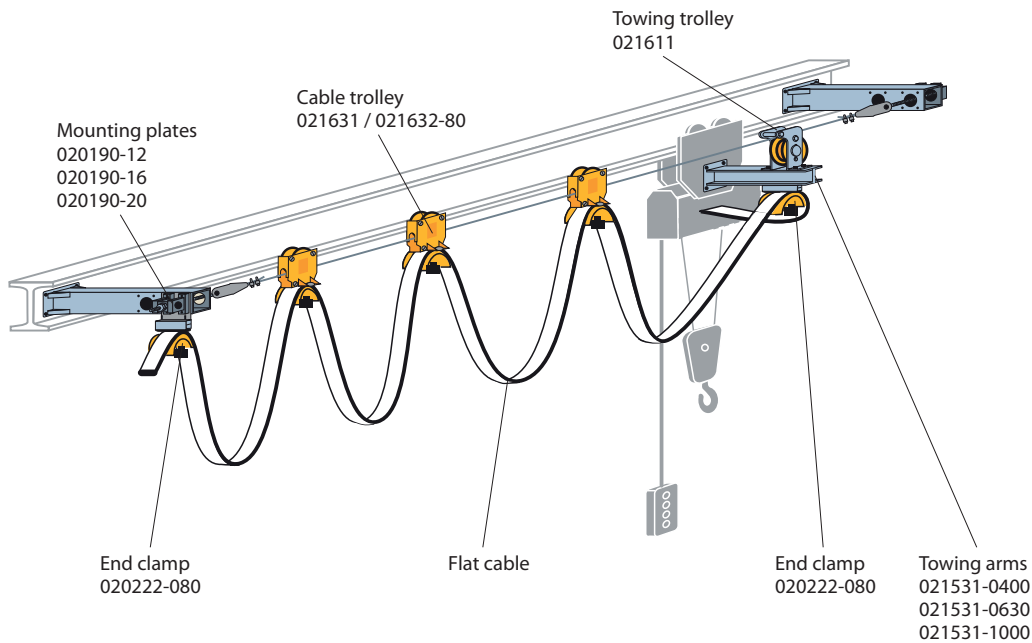

Plastic Cable Trolley with Load Capacity up to 10 kg

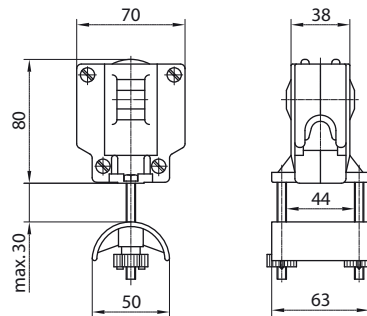

Part No : 021631

- Type of roller:
 - roller: plastic
 - axle: stainless steel
- Load capacity: 10 kg

Plastic Cable Trolley with Load Capacity up to 20 kg

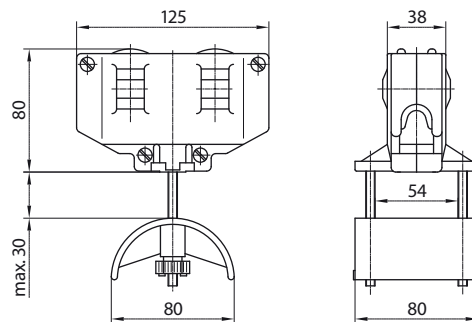

Part No . 021632-80

- Type of roller:
 - roller: plastic
 - axle: stainless steel
- Load capacity: 20 kg

Cable Trolleys for Flat Cables

Program 0215

End Clamp

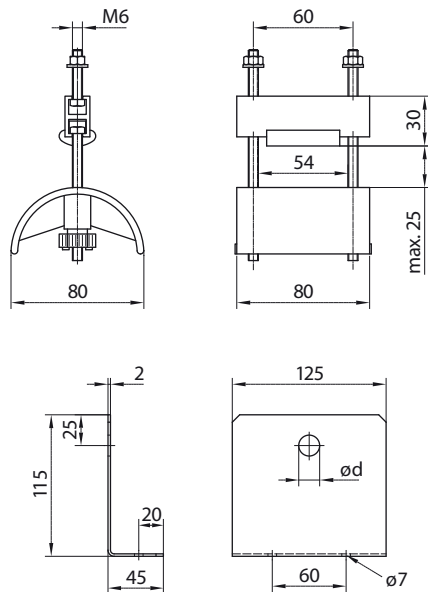

Part No : 020222-080

Note
Mounting under plate 020190
and towing arm 021531

Mounting Plate Part No	ø d [mm]	Suitable Straining Screw
020190-12	13	020187-12
020190-16	17	020187-16
020190-20	21	020187-20

Towing Trolley with Rope Guidance

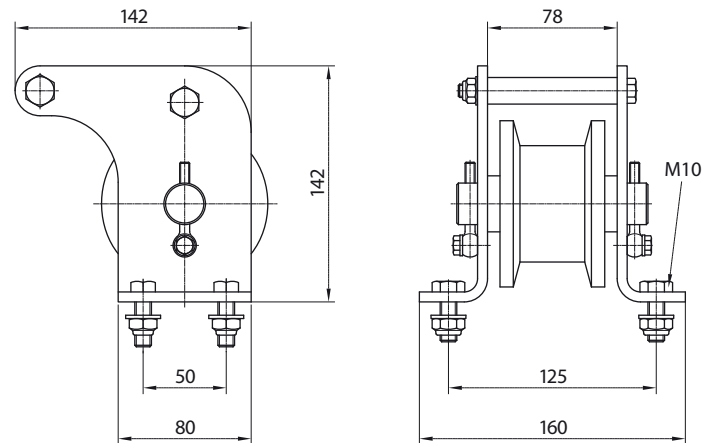

Part No : 021611
 • Casing: galvanized steel
 • Type of roller:
 - roller: plastic, with steel ball bearing
 - axle: galvanized steel

Towing Arm

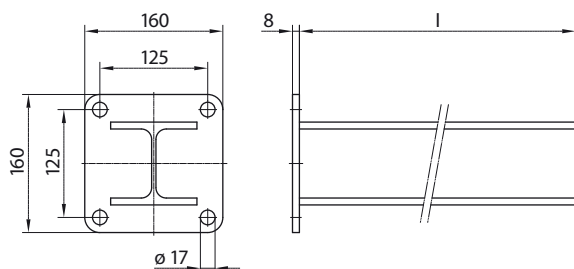

Part No	l [mm]	Material
021531-0400	400	galvanized steel
021531-0630	630	
021531-1000	1000	

Cable Trolleys for Round Cables and Hoses Program 0210

Festoon Systems for Round Cables on Rope with Diameter 6 mm

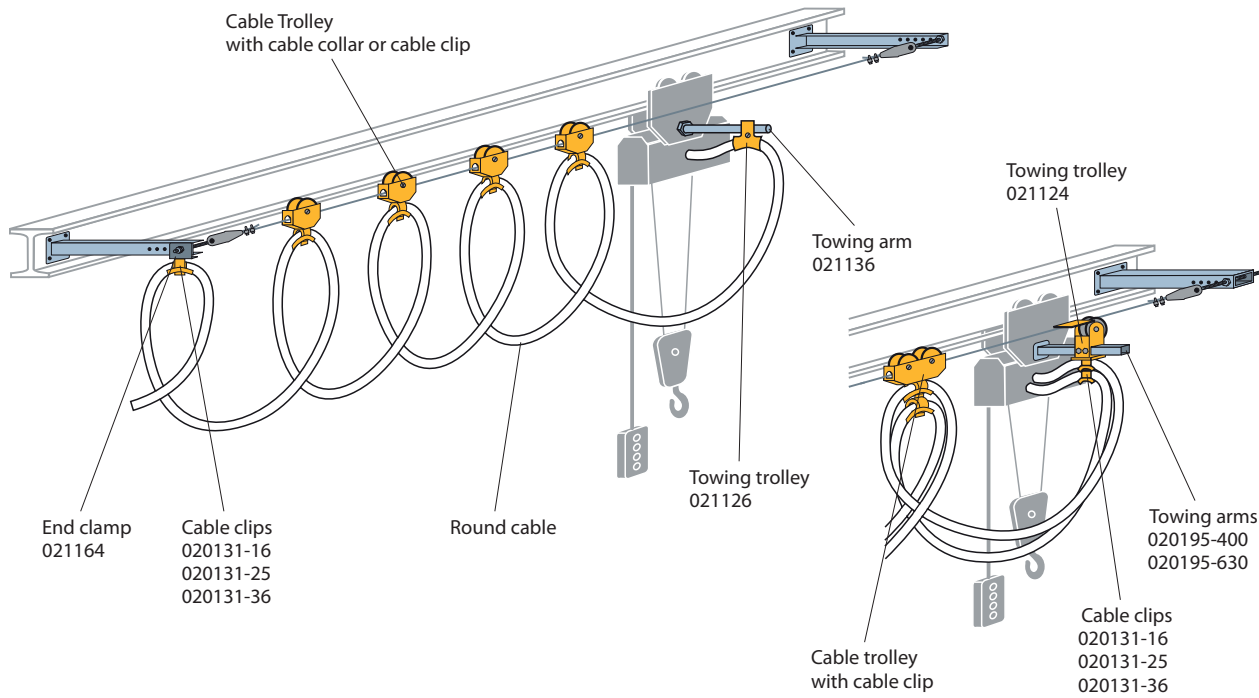

Plastic Cable Trolley with Hook or Eye with Load Capacity up to 3 kg

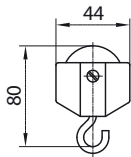

Trolley with Hook
Part No : 021111
Load capacity: 3 kg

Note
Corresponding cable clip
020131 see page 9

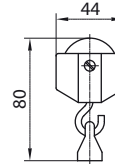

Trolley with Eye
Part No : 021115
Load capacity: 3 kg

Plastic Cable Trolley with Hook or Eye with Load Capacity up to 6 kg

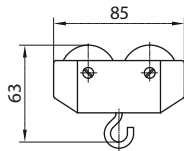

Trolley with Hook
Part No : 021112
Load capacity: 6 kg

Note
Corresponding cable clip
020131 see page 9

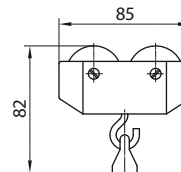

Trolley with Eye
Part No : 021116
Load capacity: 6 kg

Cable Collars for Trolleys with Hook



Part No	Cable Diameter [mm]
020111-10	10
020111-12,5	12,5
020111-14	14
020111-16	16
020111-18	18
020111-20	20

Round Cable Trolleys and Hoses Program 0210

Plastic Cable Trolley with Ball Joint with Load Capacity up to 6 kg

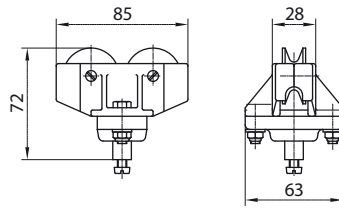

Part No : 021117
Load capacity: 6 kg

End Clamp

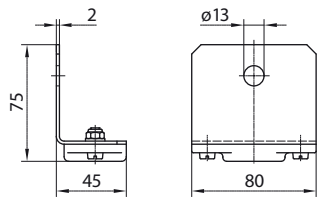

Part No : 021164

Note
Suitable cable clip 020131

Cable Clips for Trolleys with Hook or Ball Joint



Part No	Cable Diameter [mm]
020131-16	10 - 16
020131-25	17 - 25
020131-36	26 - 36

Note
The cable clips can be combined in multiple variations.

Cable Support and Towing Arm

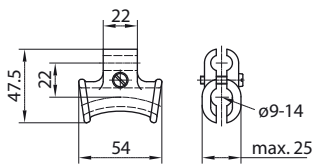

Part No : 021126

Note
Only for one cable.
Mounting of additional clips not possible.

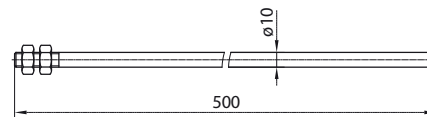

Towing Arm
Part No : 021136
Material: galvanized steel

Towing Trolley with Rope Guidance

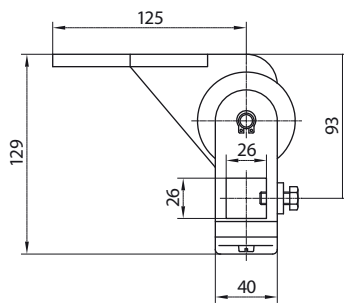

Towing trolley

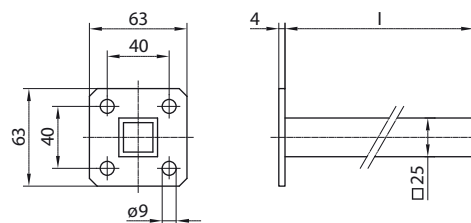
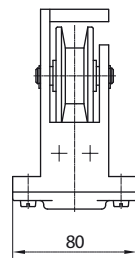

Towing arm

Towing Arm Part No	l [mm]
020195-400	400
020195-630	630

Part No : 021124

Note
Suitable cable clip 020131

Cable Trolleys for Round Cables and Hoses Program 0215

Festoon Systems for Round Cables on Ropes with Diameter 8-12 mm

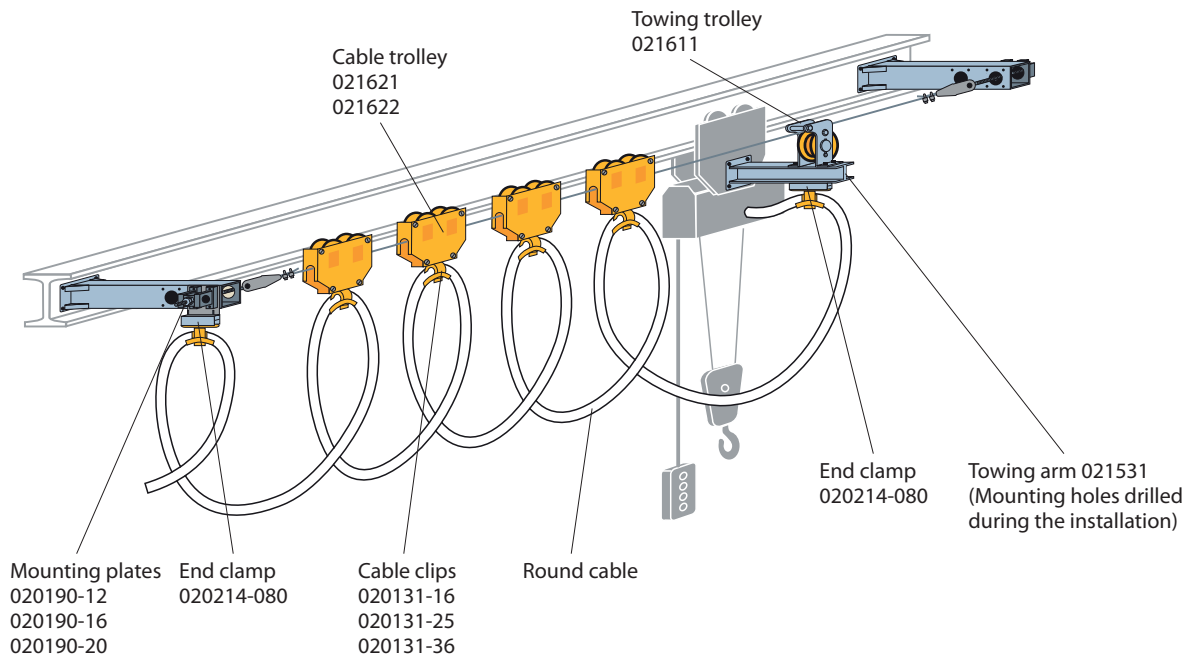

Plastic Cable Trolley with Load Capacity up to 10 kg

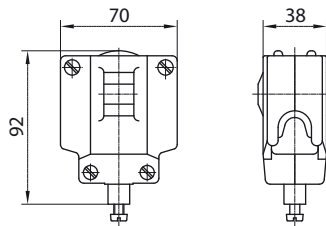

- Part No . 021621
- Type of roller:
 - roller: plastic
 - axle: stainless steel
 - Load capacity: 10 kg

Suitable cable clips 020131
see page 9

Plastic Cable Trolley with Load Capacity up to 20k

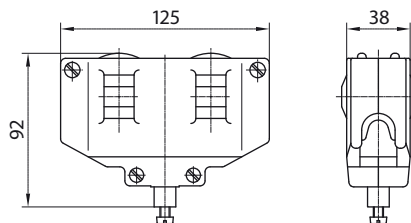

- Part No : 021622
- Type of roller:
 - roller: plastic
 - axle: stainless steel
 - Load capacity: 20 kg

Suitable cable clips 020131
see page 9

Round Cable Trolleys and Hoses Program 0215

End Clamp

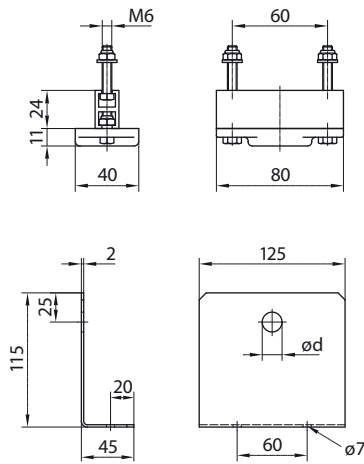

End Clamp
Order No. 020214-080

Notes

- Mounting under plate 020190 and towing arm 021531
- Suitable cable clip 020131

Mounting Plate Part No	ød [mm]	Suitable Straining Screw
020190-12	13	020187-12
020190-16	17	020187-16
020190-20	21	020187-20

Towing Trolley with Rope Guidance



Towing Trolley Order No. 021611
Towing Arm Part No : 021531

For more details see page 7

Supplements to the Program on Inquiry



Trolley running on two ropes
Double load capacity



Ideal Control Unit Trolley
for Flat and Round Cables

Helpful Hints

Calculation of Tensile Force

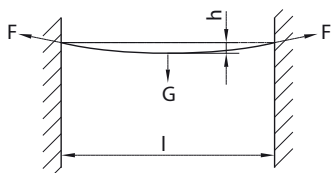

In planning a flexible cable system it is necessary to calculate the carrying capacity of the rope. Normally plastic covered steel ropes are used which are suitable for most applications.

- F [kN] = Tensile force in the rope
- G [kg] = Total load of netweight of rope plus weight of cable trolleys and cables
- l [m] = Span width of rope
- h [m] = Sag of rope
- g [m/s²] = Gravitational acceleration = 9.81
- φ = Net load factor = 1.1-1.2 to DIN 15018, section 4.1.4.1
Consideration is recommended.

The tensile force can be calculated approx. using the following formula:

$$F = \frac{\varphi \cdot G \cdot l \cdot g}{8000 \cdot h} \leq F_{perm.} \text{ [kN]}$$

Determination of Rope Load and Selection of Required Rope

The required rope can be determined with the help of the following diagrams. The diagrams were issued with $\nu=1,2$ and $\delta=4$.

Program 0210

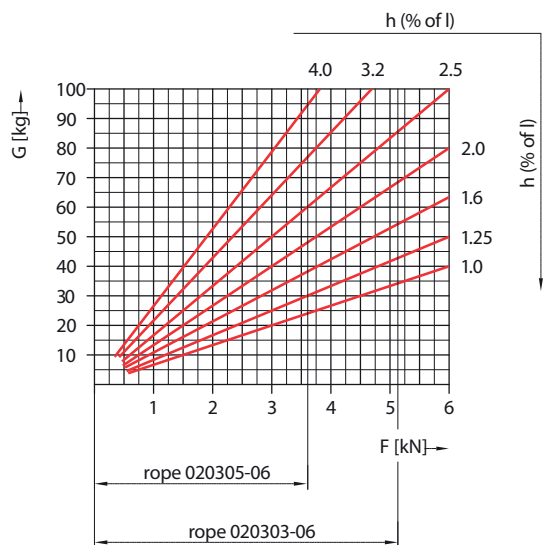

Program 0215

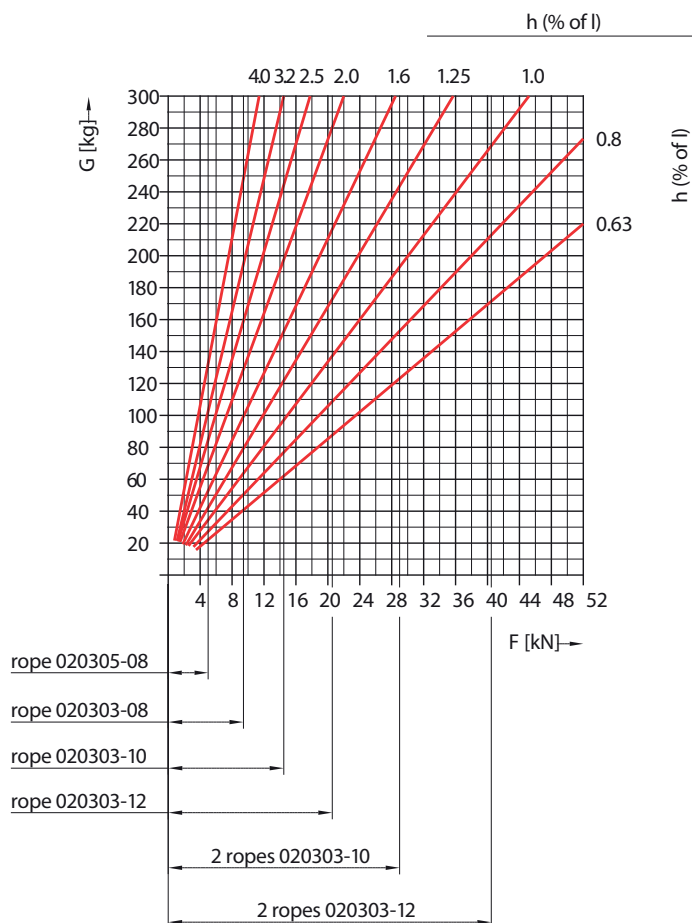

Calculation Example

Given:

- Total load G = 145 kg
- Span width l = 100 m
- Rope sag $h_{perm.} = 2 \text{ m} = 2\%$

Calculated values:

- Diagram program 0210: not suitable
- Diagram program 0215: suitable

From diagram program 0215

- existing rope load $F = 10,5 \text{ kN}$
- required rope : 020303-10

Your Applications - our Solutions!

Festoon Systems by Conductix-Wampfler are only one part of the wide range of the Conductix-Wampfler energy, data and air/fluid supply systems. The right solution for your application is always dependant on the specific situation.

Many times, it is the precise combination of several Conductix-Wampfler systems that will yield the best results. You will find consulting and engineering competence in our companies and subsidiaries worldwide - a perfect complement to our wide array of products and systems.



Festoon systems

It is hard to imagine Conductix-Wampfler cable trolleys not being used in virtually every industrial application: They are reliable and robust in an enormous variety of dimensions and designs.



Cable reels

Motorized and spring cable reels by Conductix-Wampfler are proven solutions wherever energy, data and media have to cover the most diverse distances within a short amount of time - in all directions, fast and safe.



Slip ring assemblies

Whenever things are really "moving in circles", the proven slip ring assemblies by Conductix-Wampfler ensure the flawless transfer of energy and data. Here, everything revolves around flexibility and reliability!



Conductor rails

Whether they are enclosed conductor rails or expandable single-pole systems, the proven conductor rails by Conductix-Wampfler reliably move people and material.



Non-insulated conductor rails

Extremely robust, non-insulated conductor rails with copper heads or stainless steel surfaces provide the ideal basis for rough applications, for example in steel mills or shipyards.



Energy guiding chains

The "Jack of all trades" when it comes to transferring energy, data, air and fluid hoses. With their wide range, these energy guiding chains are the ideal solution for many industrial applications.



Inductive Power Transfer IPT

The no-contact system for transferring energy and data. For all tasks that depend on high speeds and absolute resistance to wear.

Noremak Industries Pty Ltd
1 Ledger Road Beverley SA 5009
2 Roni Court Winnellie NT 0820
Phone 08 8244 7288 Fax 08 8244 7299
sales@noremak.com.au
www.noremak.com.au